

Gemini 1/2" Diaphragm Pumps

Max. Flow – Pump #818830 (SS), #818832 (Polypro), #818833 (Polypro), #818836 (Acetal), #818837 (Alum),
 Low Pulse – #818831 (Acetal), #818834 (SS), #818835 (Polypro), #818838 (Alum)

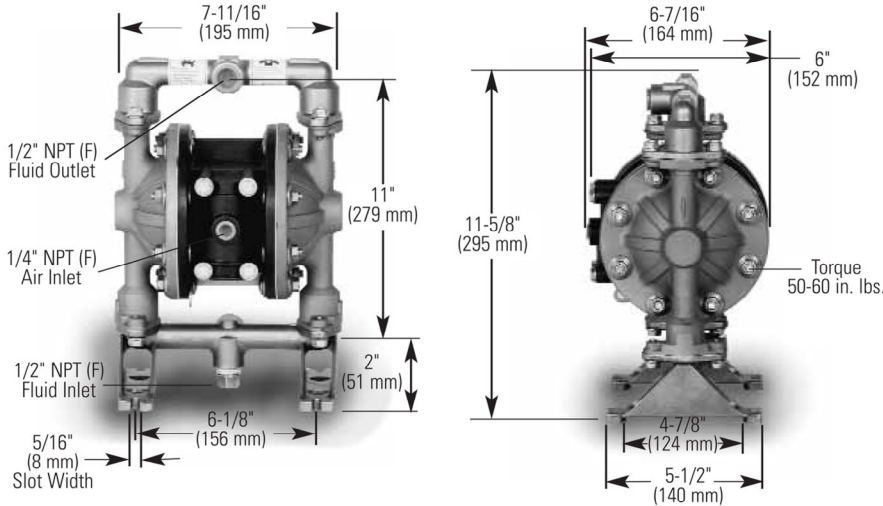

NOTE: Stainless Steel Pump Shown. Groundable Acetal and Polypropylene have 4 inlets and 4 outlets

Performance – 100 PSI

Air Inlet Pressure 20 - 100 PSI (1 - 6.9 bar)
 Fluid Pressure 20 - 100 PSI (1 - 6.9 bar)
 Max. Flow Rate (Flooded Inlet)
 Standard Stroke
 SS and Polypropylene 13-GPM (49.2 lpm)
 Short Stroke
 Groundable Acetal 7-GPM (26.5 lpm)
 Max. Particle Size 3/32" Dia (2.4 lpm)
 Max. Temperature Limits
 Stainless Steel 200° F (93° C)
 Groundable Acetal 180° F (82° C)
 Polypropylene 150° F (66° C)
 Flows @ 60 Cycles/Min.
 Standard Stroke 2.4 Gal (9 liters)
 Short Stroke 1.32 Gal (5 liters)
 Cycles Per Gallon (Liter)
 Standard Stroke 25(6.6)
 Short Stroke 45.5(512)
 Displacement Per Cycle - Standard Stroke
 9.24 cu. in. (151.4 cm³)
 5.12 oz. (151.4 ml)
 .040 gal. (.15 liter)
 Short Stroke
 5.08 cu. in. (83.3 cm³)
 2.8 oz. (83.3 ml)
 .022 gal. (.08 liter)
 Noise Level with muffler
 @ 70 PSI @ 60 Cycles/Min. 71.1 db(A)

Gemini Bare Pumps 1/2", Low Pulse

MODEL	SIZE	RATIO	GPM PER CYCLE	GPM @ 60 CPM	GPM @ MAX. CPM	BODY	WETTED MATERIAL CONSTRUCTION		
							SEATS	BALLS	DIAPHRAGMS
818831	1/2"	1:1	0.02	1.2	7	Acetal	SS	SS	Teflon
818834	1/2"	1:1	0.02	1.2	7	SS	SS	SS	Teflon
818835	1/2"	1:1	0.02	1.2	7	Polypro	SS	Santo	Santoprene
818838	1/2"	1:1	0.02	1.2	7	Alum	SS	SS	Teflon

Gemini Bare Pumps 1/2", Max. Flow

MODEL	SIZE	RATIO	GPM PER CYCLE	GPM @ 60 CPM	GPM @ MAX. CPM	BODY	WETTED MATERIAL CONSTRUCTION		
							SEATS	BALLS	DIAPHRAGMS
818830	1/2"	1:1	0.04	2.4	13	SS	SS	SS	Teflon
818832	1/2"	1:1	0.04	2.4	13	Polypro	SS	Santo	Santoprene
818833	1/2"	1:1	0.04	2.4	13	Polypro	SS	SS	Teflon
818836	1/2"	1:1	0.04	2.4	13	Acetal	SS	SS	Teflon
818837	1/2"	1:1	0.04	2.4	13	Alum	SS	SS	Teflon

Available Accessories

Air Filter/Regulator 849303
 Wall Mount Bracket 873116
 Siphon 5 ft. hose w/fluid filter (5 gal) 874504

Gemini 1/2" Low Pulse
Cycles Per Minute (CPM)

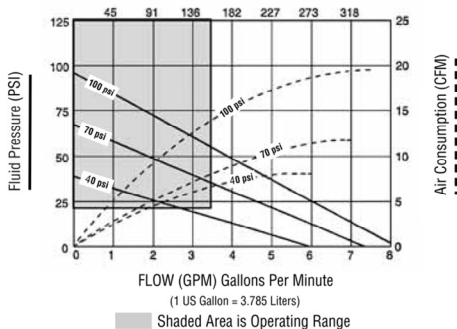

Gemini 1/2" Max. Flow
Cycles Per Minute (CPM)

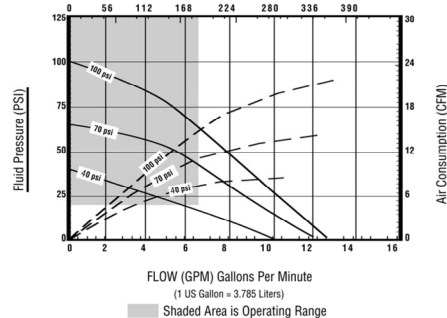

分公司服務處電話：
 台中:886-4-23588755
 台南:886-6-2709257
 北京:86-10-64882666轉8008
 天津:86-22-58853955
 上海:86-21-64839459
 昆山:86-512-57458588
 寧波:86-574-63320852
 東莞:86-769-85415416
 廈門:86-592-6074228
 煙台:86-535-6386683
 南海:86-757-81139110
 重慶:86-23-67700577



代理商：
 Baifu Technology corporation
 百富非凡機電設備有限公司
 長築實業股份有限公司

地址：台灣省新北市土城區忠承路83號9樓
 電話：+886-2-2268 4088
 傳真：+886-2-2268 4086
 Website：www.bfcoating.com
 E-mail：taipei@bfcoating.com